

Product Features

Frequency: DC ~ 8GHz
 Attenuation Range: 0.5dB LSB steps to 31.5dB
 Insertion Loss: 1.2dB@800MHz
 Input Power for 1dB Compression:
 +34dBm@800MHz
 Input Third-Order Intercept Point:
 +44.5dBm@800MHz
 Single Supply Voltage: 5V
 Package: QFN24

General Description

BR9153S is a wideband MMIC 6-bit serial/parallel digital attenuator designed using GaAs process with a 31.5 dB attenuation control range in 0.5 dB steps over the frequency range from DC to 8GHz. The digital attenuator provides typical insertion loss less than 1.2dB, and excellent attenuation accuracy and high input linearity. The product operates with a single +5V positive supply voltage, and provides a CMOS-/TTL-compatible control interface. The device also features a user-selectable power-up state and a serial output port for cascading other serial controlled components.

Application

Communication Base Stations
 Electronic Countermeasures
 Remote Sensing and Telemetry
 Short-wave and Ultrashort-wave Wireless
 Communication Equipment

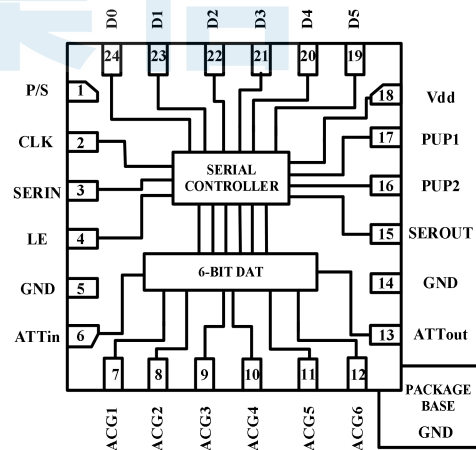
Functional Block Diagram

Ordering Information

Part Number	Package	Description
BR9153S	QFN24	DC~8GHz 6-bit Serial/Parallel Digital Attenuator

Electrical Specifications

Parameters	Test Conditions	Min.	Typ.	Max.	Units
Insertion Loss	0.001GHz to 3.0GHz	-0.8	-1.2	-1.9	dB
	3.0GHz to 8.0GHz	-1.5	-2.0	-2.8	
Attenuation Range	0.001GHz to 8.0GHz	0.5	-	31.5	dB
Input Return Loss	0.001GHz to 8.0GHz	-	-15	-	dB
Output Return Loss	0.001GHz to 8.0GHz	-	-15	-	dB
Attenuation Accuracy: (Reference state Insertion Loss) All Attenuation States	0.001GHz to 1.0GHz	±0.6			dB
	1.0GHz to 4.0GHz	±0.3			
	4.0GHz to 6.0GHz	±0.4			
	6.0GHz to 8.0GHz	±0.3			
Input Power for 1dB Compression	0.01GHz to 2.5GHz	19.1	34	34.9	dBm
Input Third-Order Interception	0.001GHz to 4.2GHz	23.1	44.5	48.5	dBm
Switching Characteristics	Test at a frequency of				
T _{rise} (50% CTL-90% RF)	200MHz and an	-	71	-	ns
T _{fall} (50% CTL-10% RF)	attenuation of 16dB	-	78	-	ns
Test Condition: V _{dd} =+5V, I=3mA, IIP3 spacing=1MHz, P _{in} =0dBm/tone, Temp=+25°C					

Absolute Maximum Ratings

Maximum Operating Voltage (Vdd) : +7V;

Max RF input Power: +27dBm (All Atten. States);

Control Voltage Range: 0V ~ Vdd;

Recommended Operating Conditions

Supply Voltage: +5V;

Supply Current: 3mA;

Control Voltage: 0 ~ 0.8V (Low Level);

2.7V ~ Vdd (High Level);

PUP1/PUP2 Control Voltage:

0 ~ 0.8V (Low Level);

Vdd-0.5 ~ Vdd (High Level);

Storage Temperature: -65°C ~ +150°C;

Operating Temperature: -55°C ~ +125°C;

Note: Operation of the device outside the parameter ranges given absolute-maximum-ratings conditions may cause permanent damage, and exposure to absolute-maximum-ratings conditions for extended periods will affect the reliability.

博瑞集信

ESD WARNING

ELECTROSTATIC SENSITIVE DEVICE

OBSERVE HANDLING PRECAUTIONS

Typical Performance (EVB test results)

Parameters	Typ.							Units
Frequency	1	30	100	400	600	800	1000	MHz
Reference State Insertion Loss	-0.9	-1.1	-1.1	-1.2	-1.2	-1.2	-1.3	dB
Attenuation Accuracy (0.5dB)	0	0	0	0	0	-0.1	0	dB
Attenuation Accuracy (1 dB)	0	0	-0.1	0	0	-0.1	0	dB
Attenuation Accuracy (2 dB)	-0.1	0	-0.1	-0.1	-0.1	-0.1	-0.1	dB
Attenuation Accuracy (4 dB)	0	0	-0.1	-0.1	-0.1	-0.1	-0.1	dB
Attenuation Accuracy (8 dB)	0.4	0.4	0.3	0.1	0	0	0.1	dB
Attenuation Accuracy (16 dB)	0.6	0.6	0.4	0.1	0	-0.1	-0.1	dB
Attenuation Accuracy (31.5dB)	0.9	0.8	0.6	0.1	-0.2	-0.6	-0.2	dB
Input Return Loss	-19.0	-20.7	-20.7	-19.7	-19.0	-18.5	-18.5	dB
Output Return Loss	-18.5	-20.5	-20.5	-19.7	-19.4	-19.1	-19.2	dB
Input Power for 1dB Compression	-	20.9	23.5	33.4	33.5	34.0	34.3	dBm
Switching Characteristics	80.6 (T _{rise})				61.9 (T _{fall})			ns

 Test Conditions: V_{dd}=+5V, I=3mA, Temp=+25°C

Parameters	Typ.							Units
Frequency	1600	2000	2600	3000	3600	4000	4600	MHz
Reference State Insertion Loss	-1.5	-1.6	-1.7	-1.8	-1.8	-1.9	-1.8	dB
Attenuation Accuracy (0.5dB)	0	0	0	0	0	0	-0.1	dB
Attenuation Accuracy (1 dB)	0	0	0	-0.1	0	0	-0.2	dB
Attenuation Accuracy (2 dB)	-0.1	0	-0.1	-0.1	-0.1	-0.1	-0.2	dB
Attenuation Accuracy (4 dB)	-0.1	-0.1	-0.1	-0.1	-0.1	-0.1	-0.2	dB
Attenuation Accuracy (8 dB)	0.1	0.1	0.1	0.1	0.1	0.1	-0.1	dB
Attenuation Accuracy (16 dB)	0	-0.1	-0.1	-0.1	0	-0.1	-0.3	dB
Attenuation Accuracy (31.5dB)	-0.2	-0.1	-0.2	-0.3	-0.5	-0.7	-0.4	dB
Input Return Loss	-19.1	-20.5	-20.0	-18.3	-19.3	-22.4	-31.4	dB
Output Return Loss	-20.5	-21.5	-19.0	-17.2	-16.7	-19.0	-30.6	dB
Input Power for 1dB Compression	34.6	34.9	-	-	-	-	-	dBm
Switching Characteristics	80.6 (T _{rise})				61.9 (T _{fall})			ns

 Test Conditions: V_{dd}=+5V, I=3mA, Temp=+25°C

Parameters	Typ.							Units
	5000	5600	6000	6600	7000	7600	8000	
Frequency	5000	5600	6000	6600	7000	7600	8000	MHz
Reference State Insertion Loss	-2.1	-2.3	-2.8	-2.7	-2.2	-2.6	-2.3	dB
Attenuation Accuracy (0.5dB)	0	0	0	0.1	0.1	0	0	dB
Attenuation Accuracy (1dB)	-0.1	-0.1	0	0.1	0	-0.1	-0.1	dB
Attenuation Accuracy (2dB)	-0.2	-0.1	0	0.1	0	-0.1	-0.1	dB
Attenuation Accuracy (4dB)	-0.2	-0.1	0	0.1	0	0	0	dB
Attenuation Accuracy (8dB)	-0.2	-0.1	0.2	0.3	0.2	0.2	0.3	dB
Attenuation Accuracy (16dB)	-0.3	-0.1	0.1	0.3	0.3	0.3	0.5	dB
Attenuation Accuracy (31.5dB)	-0.7	-0.2	-0.2	0.3	0	0.3	0.6	dB
Input Return Loss	-20.7	-13.4	-11.4	-11.1	-12.6	-19.7	-25.2	dB
Output Return Loss	-22.7	-14.5	-11.8	-11.1	-12.6	-18.4	-21.3	dB
Input Power for 1dB Compression	-	-	-	-	-	-	-	dBm
Switching Characteristics	80.6 (T _{rise})				61.9 (T _{fall})			ns

Test Conditions: V_{dd}=+5V, I=3mA, Temp=+25°C

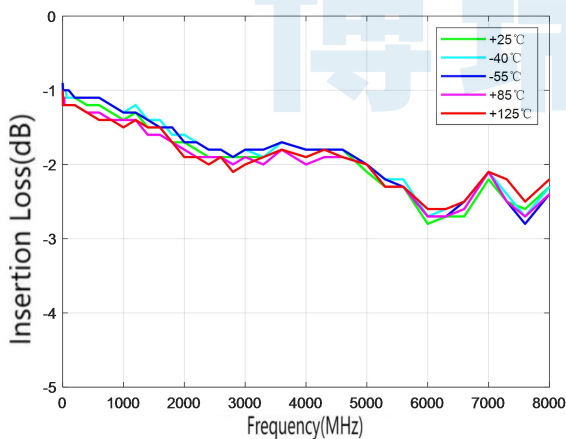
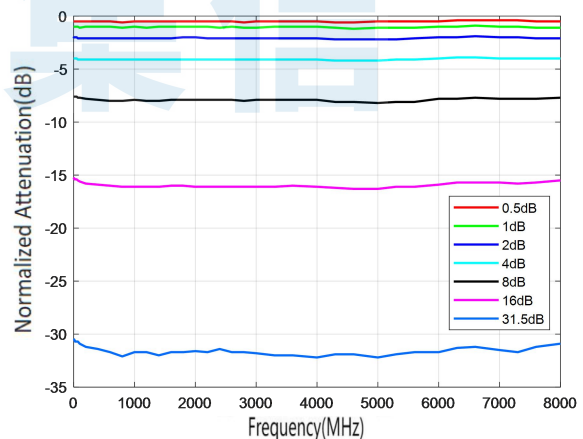

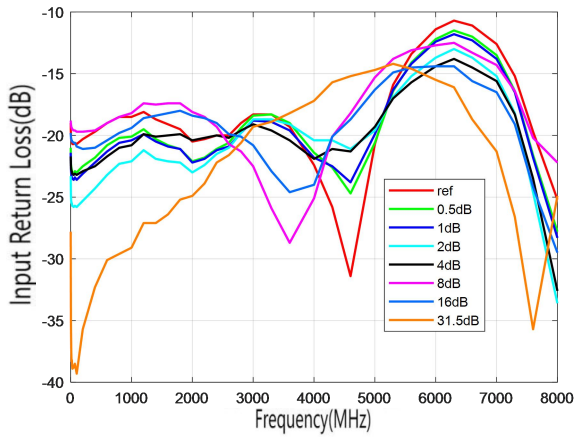
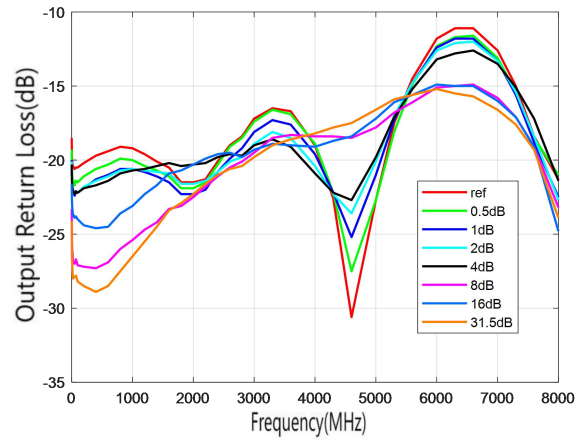
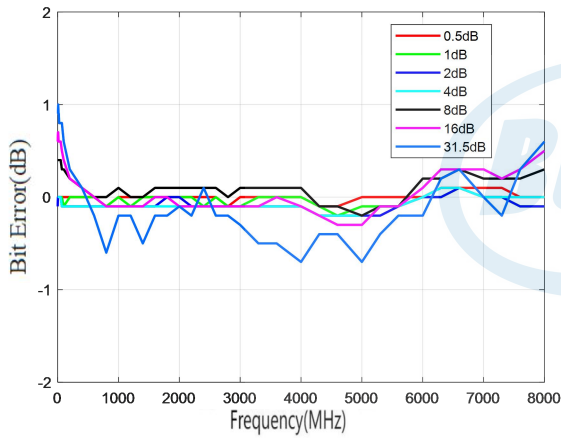
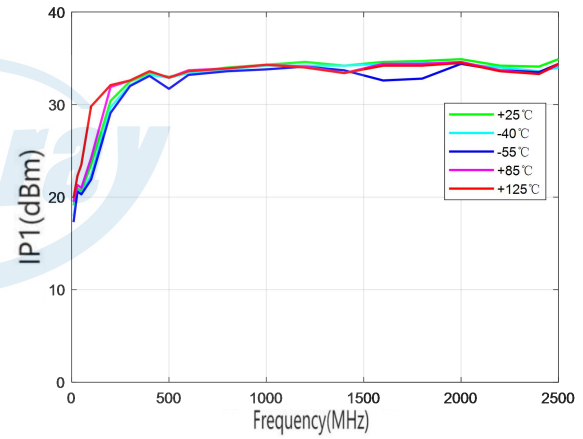
Insertion Loss

Normalized Attenuation

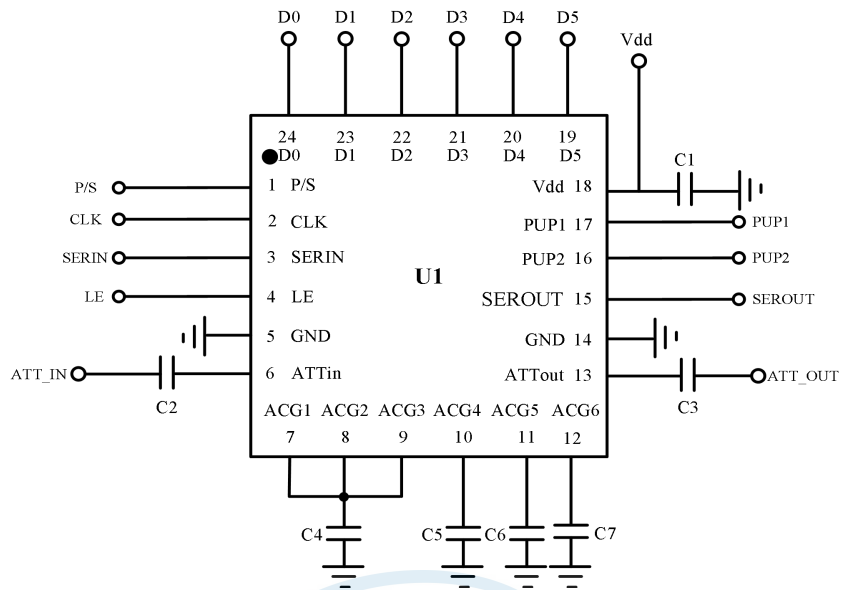
Input Return Loss

Output Return Loss

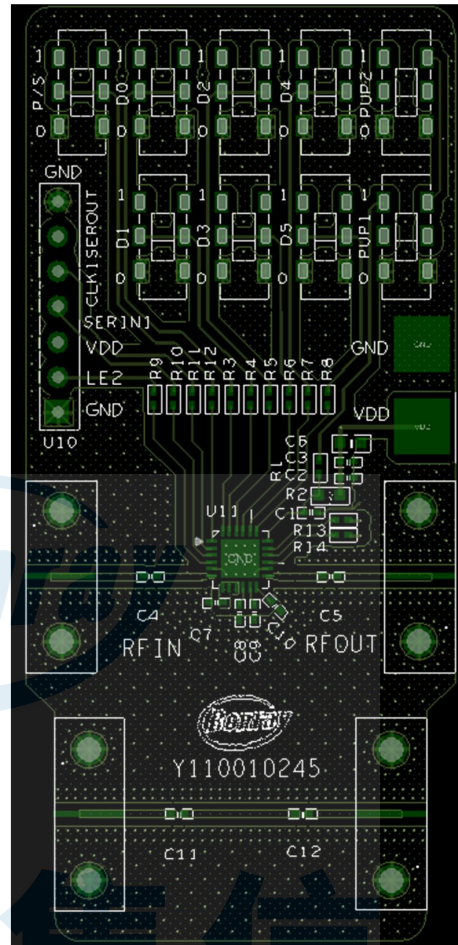
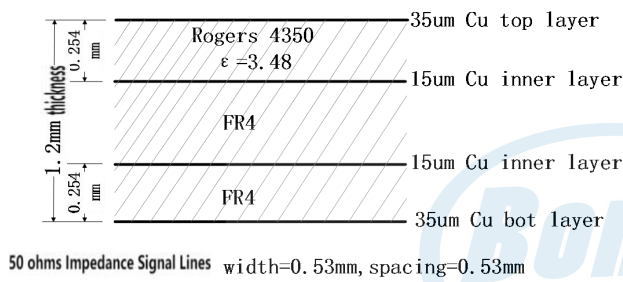
Bit Error

Input Power for 1dB Compression

博瑞集信

Typical Application Schematic

Bill of Material

Designator	Package	Description	Part Number
C1	0402	1000pF	C0402C102J1GACACAUTO
C2, C3	0402	100nF	GRM155R71C104KA88
C4~C7	0402	1uF	GRM1555C1H105JA01

PCB Evaluation Board

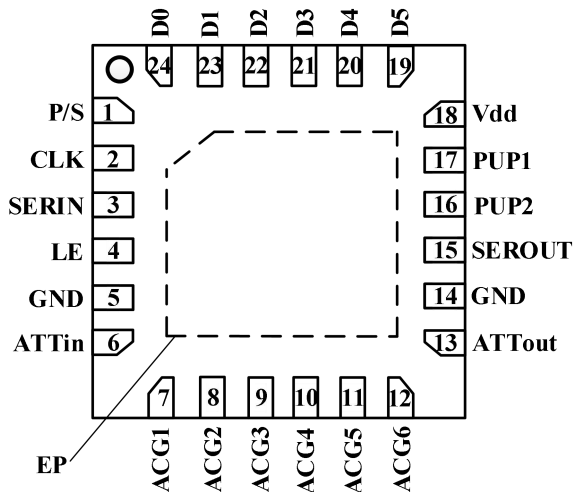
博瑞集信

Pin Configuration and Description

Pin Numbers	Pin Name	Description
1	P/S	Parallel/Serial mode selection pin. See Mode Selection Truth Table.
5, 14	GND	RF/DC ground pins. Connect to ground.
7 to 12	ACG1~ACG6	AC Grounding Capacitor Pins. External capacitors to ground are recommended. Place capacitor as close to pins as possible.
6, 13	ATTin, ATTout	Attenuator RF Input/Output. DC blocking is required.
15	SEROUT	Serial interface data output pin. Serial input data is delayed by six clock cycles.
19 to 24	D5 ~ D0	Parallel control voltage input pins. Select the required attenuation. See Parallel Control Voltage Truth Table.
2	CLK	Serial interface clock input pin.
3	SERIN	Serial interface data input pin.
4	LE	Latch enable input pin. See Mode Selection Truth Table.
16 or 17	PUP2, PUP1	Power-up state selection pins. See PUPx Truth Table.
18	Vdd	Power supply pin.
-	EP	RF/DC ground. Use recommended via pattern to minimize inductance and thermal resistant; see PCB Mounting Pattern for suggested footprint.

博瑞集信

Mode Selection

There are three control modes for BR9153S: Power-up control mode, Serial control mode, and Parallel control mode.

Mode Selection Truth Table

LE	P/S	Control Mode
Low	X	Power-up
High	Low	Parallel
High	High	Serial

Power-on State

The BR9153S uses the PUP1 and PUP2 control voltage inputs to set the attenuation value to a known value at power-up before the initial control data word is provided in either serial or parallel mode. When the attenuator powers up with LE set to low, the state of PUP1 and PUP2 determines the power-up state of the device per the PUPx Truth Table.

PUPx Truth Table

LE	PUP1	PUP2	Attenuation State
Low	Low	Low	31.5dB
Low	High	Low	-24dB
Low	Low	High	-16dB
Low	High	High	Insertion loss (Reference State)
High	X	X	Determined by D0 to D5

Serial Mode Interface

The BR9153S has a 3-wire serial peripheral interface (SPI): serial data input (SERIN), clock (CLK), and latch enable (LE). The serial control interface is activated when P/S is set to high. In serial mode, the 6-bit SERIN data is clocked MSB first on the rising CLK edges into the shift register and then LE must be toggled high to latch the new attenuation state into the device. LE must be set to low to clock new 6-bit data into the shift register because CLK is masked to prevent the attenuator value from changing if LE is kept high.

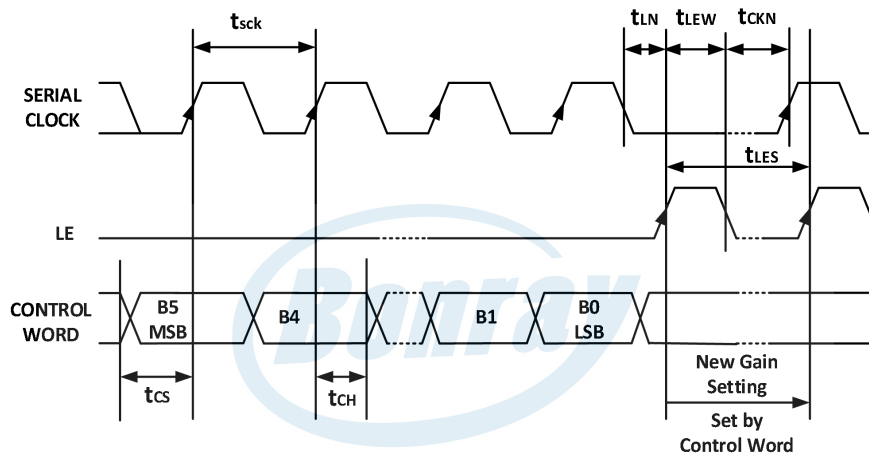

Timing Specificationse Table

Numbers	Parameters	Typ.	Numbers	Argument	Typ.
1	Minimum serial period (tSCK)	100ns	5	Minimum LE pulse width (tLEW)	10ns
2	Control setup time (tCS)	20ns	6	Minimum LE pulse spacing (tLES)	630ns
3	Control hold time (tCH)	20ns	7	Serial clock hold time from LE (tCKN)	10ns
4	LE setup time (tLN)	10ns			

Parallel Mode Interface

The BR9153S has six digital control inputs, D0 (LSB) to D5 (MSB), to select the desired attenuation state in parallel mode. The parallel control interface is activated when P/S is set to low and LE set to high.

Parallel Control Voltage Truth Table

Digital Control Input						Attenuation State RF1/RF2
D5 16dB	D4 8dB	D3 4dB	D2 2dB	D1 1dB	D0 0.5dB	
High	High	High	High	High	High	Insertion Loss(Reference)
High	High	High	High	High	Low	0.5dB
High	High	High	High	Low	High	1dB
High	High	High	Low	High	High	2dB
High	High	Low	High	High	High	4dB
High	Low	High	High	High	High	8dB
Low	High	High	High	High	High	16dB
Low	Low	Low	Low	Low	Low	31.5dB

Note: Any combination of the control voltage input states shown in this table provides an attenuation approximately equal to the sum of the bits selected.

Package Dimensions (mm)

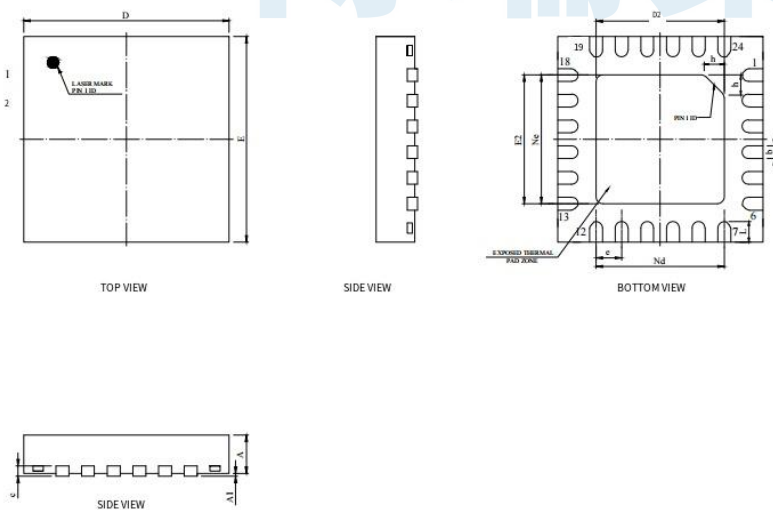

SYMBOL	MILLIMETER		
	MIN	NOM	MAX
A	0.75	0.80	0.85
A1	0.01	0.02	0.05
b	0.20	0.25	0.30
c	0.270REF		
D	3.90	4.00	4.10
D2	2.60	2.70	2.80
e	0.50BSC		
Ne	2.50BSC		
Nd	2.50BSC		
E	3.90	4.00	4.10
E2	2.60	2.70	2.80
L	0.35	0.40	0.45
h	0.35	0.40	0.45